



# SafetyRailCompany

Fall Protection for Life and Compliance



1 1/2" /

## SRC ACCU-FIT STANDING SEAM SAFETY RAIL TRADITIONAL SERIES FALL PROTECTION RAILINGS

### DESCRIPTION

The SRC Accu-Fit Traditional Standing Seam Safety Rail system is a non-penetrating, clamp-on passive fall protection barrier system that protects workers from accidental falls on flat roofs. The Accu-Fit Traditional Series railings take versatility and aesthetics into consideration by utilizing 1 1/2" schedule 40 pipe railings supported by vertical stanchions mounted into base plates. This system offers a continuous, uniform, vertical railing profile which enhances appearance and is often desirable by clients for use in high traffic areas in view of public.

### USES

The SRC Accu-Fit Traditional Standing Seam Safety Rail system is used for fall protection at unprotected, flat roof perimeters and around rooftop equipment with a roof pitch of 1:12 or less on standing seam metal roofs.

### OSHA COMPLIANCE

- Compliant with OSHA standards: (29 CFR 1910.29 & 29 CFR 1926.502)
- Independently tested by a nationally accredited engineering lab - documentation available upon request

### FEATURES

- Provides pleasing site lines and fall protection functionality
- Non-penetrating design will not compromise building envelope
- No welding or drilling required for installation
- American Welding Society Certified (AWS D1.1 & D1.3)
- 100% Made in USA
- Powder coat and galvanized finishes available
- Easily adaptable around obstructions

### MINIMUM REQUIREMENTS

- Use on standing seam metal roofs with 16", 18" or 24" wide seam pattern
- Designed for flat and low-sloped roofs, up to a 1:12 roof pitch

**DIMENSIONS**

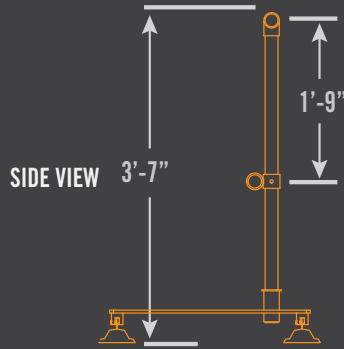

**FRONT VIEW**



**SIZE OPTIONS**

Accu-Fit Railing systems consist of three components: Base plate, stanchion and railing pipes. Base plates will compression-fit to metal roof panels. The railing pipes are typically provided in 21' lengths of 1 1/4" sch. 40 galvanized pipe. Pipes are inserted into stanchions and spliced end to end forming a continuous railing profile. Pipe is easily trimmed with power saw at corners or obstructions. This system easily adapts to a wide variety of jobsite obstacles and conditions.

**ACCU-FIT ATTACHMENT ON STANDING SEAM ROOF**



**FINISH OPTIONS**



GALVANIZED



SAFETY YELLOW + GALVANIZED



CUSTOM COLORS

**PRODUCT SPECIFICATIONS**

- Designed in accordance with OSHA Standards (29 CFR 1910.29 and CFR 1926.502)
- Tested for 200 lb (90.7kg) force in any direction
- Assembled height: 42" (107cm) top rail, 21" (53cm) mid rail
- Clamp-on base plate will not pierce metal panel
- Models for 16", 18" and 24" standing seams
- Provides high degree of safety at high risk roof edge areas
- Pleasing vertical railing sight lines integrate with building architecture
- Variety of finish options available
- 100% Made in USA
- American Welding Society Certified (AWS D1.1 & D1.3)
- All steel construction for longterm durability
- Assemble on-site modular design
- Easily trim railings at corners and obstructions



**INSTALLATION**

- Secure base plate over standing seams and secure plate to roof with supplied clamps
- Install stanchions into base plate and slide railing pipes into stanchions and secure. Trim pipes on corners or terminations
- Estimated install: 60' per hour

**PROJECT:**

**CONTRACTOR:**

**DATE:**

**Certified third party OSHA testing results available on request**